

NetGain Motors, Inc.

800 South State Street / Suite 4 / Lockport, IL 60441 / 630-243-9100 / 630-685-4054 (FAX)

User Manual

HyPer 9HV IS™

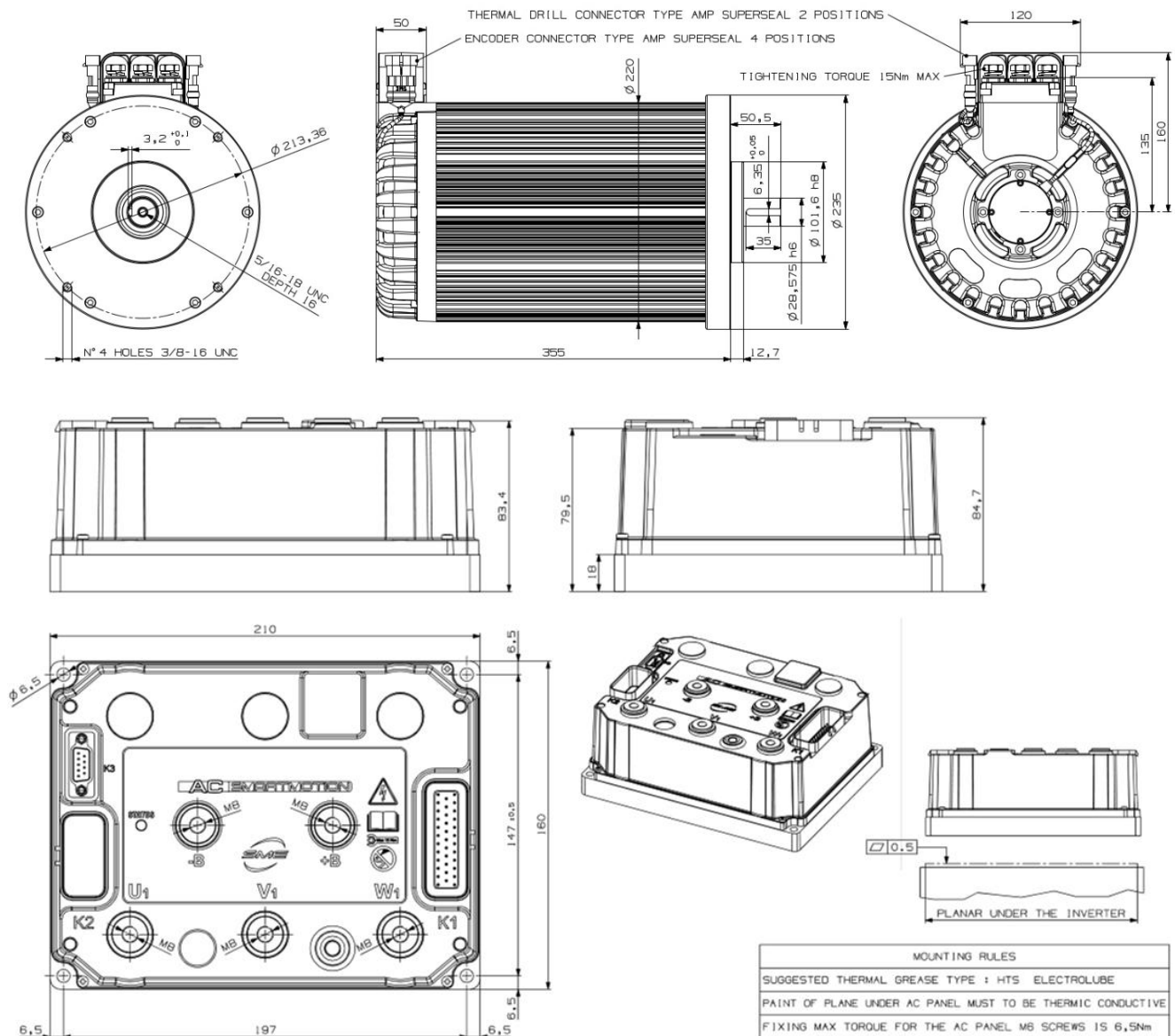

NetGain Motors, Inc.

800 South State Street / Suite 4 / Lockport, IL 60441 / 630-243-9100 / 630-685-4054 (FAX)

Table of Contents

Warning and Caution	4
Safety Information	4
DISCLAIMER:	5
X144 Main Wiring Diagram	6
X144 K1 Wire Harness Pinout	7
HyPer 9HV Motor Plug Wiring Instructions	8
HyPer 9HV Motor Plug Pinout.....	9
Motor Encoder Pin Positions	9
Motor Thermistor Pin Positions	9
X144 Main Contactor Wiring.....	10
12/24V Coil Driver, High Voltage Contacts, and Key Switch In	10
Compact Display Pinout	11
Compact Display Mating Female Plug.....	11
Pre-startup Steps	12
Download SME Smarview Sys Program:	12
Download* the Latest Controller Firmware:	12
Download* Your HyPer 9HV Clone File:.....	12
QuickStart Guide	12
Post-startup Steps.....	16
Throttle Mapping	16
Brake Regen Mapping.....	16
Regen on Neutral Operating Profiles	16
Neutral Torque Mapping	17
Battery Mapping	17
HyPer 9HV Motor Temperature Derating.....	17
X144 controller Temperature Derating.....	18
Controller Specifications	19
Controller Communication	19
Controller EMC.....	19

NetGain Motors, Inc.

800 South State Street / Suite 4 / Lockport, IL 60441 / 630-243-9100 / 630-685-4054 (FAX)

Controller Safety Certification	19
Controller Operating Environment Specifications	19
HyPer-Drive X144 Pre-Programmed I/O	20
Signal: Inputs and Outputs.....	20
Controller I/O Table	20
Diagnostic Code Guide.....	23
Additional Support.....	28
<i>Figure 1 - Standard X144 Wiring Diagram.....</i>	<i>6</i>
<i>Figure 2 - Standard X144 Wiring Diagram.....</i>	<i>6</i>
<i>Figure 3 - Standard X144 Pin Order Assignment.....</i>	<i>7</i>
<i>Figure 4 - Motor Plug Wiring Photo.....</i>	<i>8</i>
<i>Figure 5 Compact Display Male Connector.....</i>	<i>11</i>

NetGain Motors, Inc.

800 South State Street / Suite 4 / Lockport, IL 60441 / 630-243-9100 / 630-685-4054 (FAX)

Warning and Caution

Safety Information



This is not an all-inclusive list. Use common sense and act responsibly, electric motor controllers and motors are extremely powerful and could cause death, dismemberment or other serious injury if misused or not safely handled!

Wear protective or safety equipment such as safety shoes, safety glasses and gloves when working with motors and controllers.

Remove all metal jewelry and metal objects from hands, wrist, fingers, etc. before working on any electric motor or controller.

Insulate any tools that are used in proximity to connection points that have any voltage potential to prevent shorts if the tool is accidentally dropped onto the terminals/connections.

Use caution when operating any controller or motor. If you're not sure what you're doing, or do not feel comfortable with the situation, find a knowledgeable person to advise you.

Make certain the motor and controller are disconnected from any power source before servicing. If any doubt exists of the voltage that might exist, measure with proper metering devices that are in good functional condition, and rated for the voltages that could exist.

Verify and re-verify proper wiring connections.

Take extreme caution around series-connected batteries to avoid placing hands across live connections. It is generally good practice to avoid the use of both hands when working around high voltage circuits. This reduces the risk of an accidental short across the chest cavity.

If working on an electric vehicle, make certain the vehicle is positioned securely with the drive wheels safely clear of the floor and blocked up so that the drive wheels cannot make contact with the floor under any circumstances. Block the non-drive wheels if they remain in contact with the floor so that the vehicle cannot roll in either direction.

Motors and controllers must only be connected to a power source by knowledgeable and experienced personnel.

NetGain Motors, Inc.

800 South State Street / Suite 4 / Lockport, IL 60441 / 630-243-9100 / 630-685-4054 (FAX)

Motors should NEVER be run without a load. Running a motor without a load could result in harm to people or the motor. Absence of a load is considered misuse and could prove dangerous to anyone in the vicinity and void the motor warranty.

Portions of the motor or controller may become hot and proper precautions must be taken.

Motors and controllers should never be operated beyond the limits established by the manufacturer.

Motors and controllers must not be modified in any manner; doing so will void warranty and could prove extremely dangerous.

Motors are heavy and are likely to become damaged if dropped, or cause damage to anything they fall upon (including people and body parts). Use extreme caution when working with motors!

Motors contain moving parts that could cause severe injury if the proper precautions are not taken. Never touch an operating motor.

Do not defeat any safety circuits or safety devices.

Under no circumstances should you push in any contactor of an electric vehicle while the drive wheels are in contact with the floor. Pushing in a contactor when the drive wheels are in contact with the floor can cause serious property damage, personal injury or death.

DISCLAIMER:

NetGain Motors, Inc. has no control of third party installation procedure or the use of this motor and control system. Accordingly NetGain Motors, Inc. assumes no liability for vehicle functionality or safety during or after third party installation of the motor and controller. It is the responsibility of the vehicle designer and component installer to test and qualify their application and ensure proper safety and functionality. NetGain Motors, Inc assumes no responsibility for this product in any use.

NetGain Motors, Inc.

800 South State Street / Suite 4 / Lockport, IL 60441 / 630-243-9100 / 630-685-4054 (FAX)

X144 Main Wiring Diagram

X144 ONLY!

12V-24V
Key Switch

For X1 wiring see:
HyPer 9 IS User
Manual

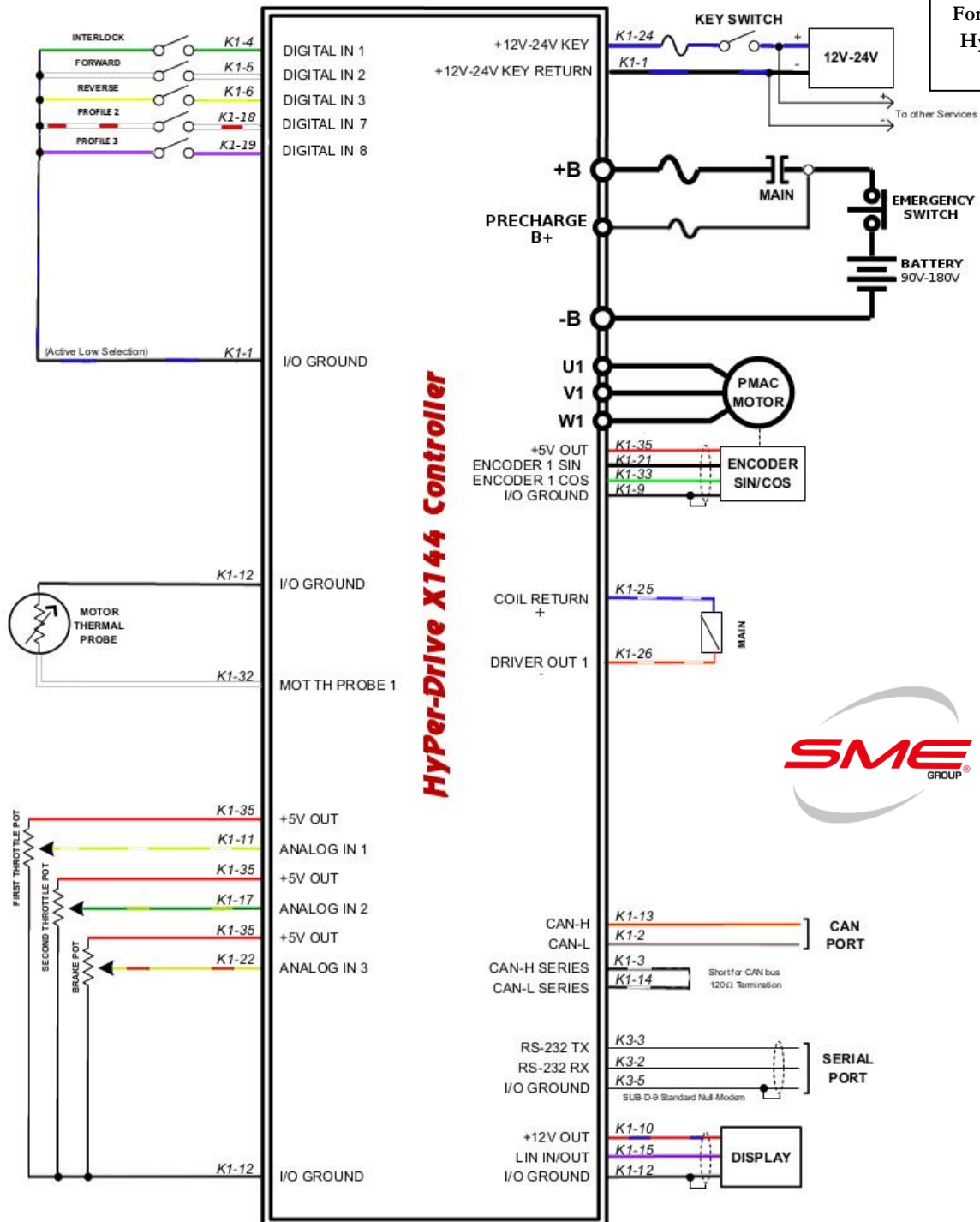

Figure 2 - Standard X144 Wiring Diagram

NetGain Motors, Inc.

800 South State Street / Suite 4 / Lockport, IL 60441 / 630-243-9100 / 630-685-4054 (FAX)

X144 K1 Wire Harness Pinout

Ampseal 35 Pin Connector:



K1 Pin Order Assignment

Length	K1 Pin#	Size	Color	Rating
11 ft	1 — I/O Ground	18 AWG	BLK/BLU	500mA
11 ft	2 — CAN Low	20 AWG	GREY	3.5V
11 ft	4 — Interlock	18 AWG	GREEN	12V 500mA
11 ft	5 — Forward Switch	18 AWG	WHITE	12V 500mA
11 ft	6 — Reverse Switch	18 AWG	YELLOW	12V 500mA
11 ft	7 — Clutch Switch	18 AWG	WHT/BLU	12V 200mA
8 ft	9 — Encoder Ground	20 AWG	BLK Under RED	500mA
11 ft	10 — 12V +	18 AWG	RED/BLU	12V 200mA
11 ft	11 — Throttle Wiper 1	18 AWG	YLW/WHT	12V 500mA
11 ft	12 — Analog Ground	18 AWG	BLACK	500mA
8 ft	12 — Thermistor Ground	20 AWG	BLK under GRN	500mA
11 ft	13 — CAN High	20 AWG	ORANGE	3.5V
11 ft	17 — Throttle Wiper 2	18 AWG	GRN/YLW	12V 500mA
11 ft	18 — Profile 2 switch	18 AWG	WHT/RED	12V 500mA
11 ft	19 — Profile 3 Switch	18 AWG	PURPLE	12V 500mA
8 ft	21 — Encoder SIN1	20 AWG	BLK under BLU	5V
11 ft	23 — Brake Pot Wiper	18 AWG	YLW/RED	12V 500mA
11 ft	24 — Key Switch In	18 AWG	BLUE	12V 8A
11 ft	25 — Coil Return +	18 AWG	BLU/WHT	12V 8A
11 ft	26 — Driver Out -	18 AWG	ORG/WHT	12V 8A
11 ft	30 — Deceleration Lights	18 AWG	ORG/RED	12V 500mA
8 ft	32 — Motor Thermistor	20 AWG	WHT under GRN	12V
8 ft	33 — Encoder COS1	20 AWG	GRN under BLU	5V
11 ft	35 — 5 Volt +	18 AWG	RED	5V 5A
	35 — Encoder 5 Volt +	20 AWG	RED under RED	5V 5A

Motor Plug Multipair Cable

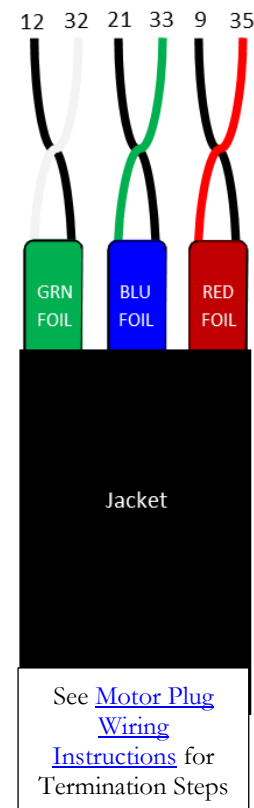

Must Be Assigned

Figure 3 - Standard X144 Pin Order Assignment

NetGain Motors, Inc.

800 South State Street / Suite 4 / Lockport, IL 60441 / 630-243-9100 / 630-685-4054 (FAX)

HyPer 9HV Motor Plug Wiring Instructions

1. Choose a location to fasten the Male 4P and 2P Receptacles from your HyPer Motor.
2. Route multipair cable at least 6 inches from the motor case. Fasten this cable securely so it is restrained from movement. Line cable up with motor's Male Receptacles.
3. Using Cable Cutters - trim excess length from multipair cable, leave 4-6" extra to ensure cable will reach motor Receptacles.
4. Using a co-ax stripper or scissors – carefully strip multipair black jacket at least 4.5" from cable end. This length should allow 4P and 2P wires to reach their respective Receptacle. Be careful not to cut into the foil shielding or wire insulation underneath the jacket. A razor blade or X-acto knife can be used to carefully slice a relief strip down the stripped jacket length, so it can be easily removed.
5. Slide ½" diameter heatshrink over multipair cable. Slide heatshrink past the newly exposed foil, and rest heatshrink on remaining jacket material for future adhesion.
6. Slide ¼" diameter heatshrink over each of the 3 shielded twisted pairs. Rest heatshrink near jacket for future adhesion.
7. Peel back 1.5" of foil shield and plastic wrap.
8. Slide yellow Plug Seals onto each wire with the smaller diameter end of each Seal facing the wire end.
9. Strip ¼" of insulation from the end of each 20awg wire.
10. Using an Open Barrell Crimper for "Amp" brand Pins – Crimp the provided "Strip Pins" onto the copper of each wire.
11. Place pins in their proper position according to [Motor Plug Pinout](#) on the next page.
12. Fasten the red locking plate on the front of each plug. Verify all six pins are fully inserted.
13. Slide yellow Plug Seals into wire cavities.
14. Plug the newly assembled Plugs into the matching Male Plugs on your HyPer motor.
15. After the pre-start up steps are complete, and correct system operation is verified, apply heat to heatshrink using a heat gun. Adhere the heatshrink as close to the plug as possible without putting strain on the inserted wires.

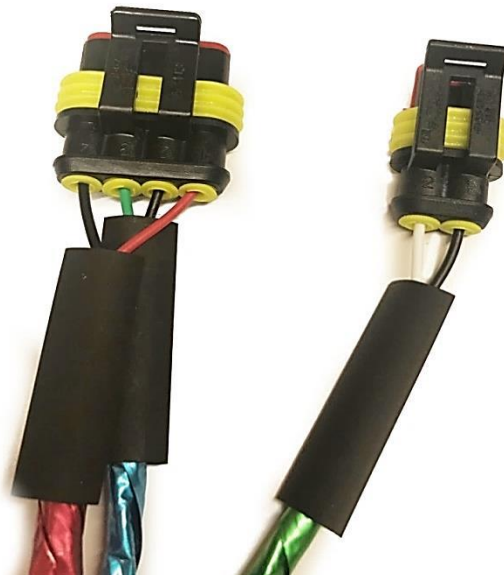

Figure 4 - Motor Plug Wiring Photo

NetGain Motors, Inc.

800 South State Street / Suite 4 / Lockport, IL 60441 / 630-243-9100 / 630-685-4054 (FAX)

HyPer 9HV Motor Plug Pinout

Important: The Motor Encoder must be mounted securely and restrained from movement. Keep Encoder wires as far as possible from High Voltage cables and the motor's field.

Motor Encoder Pin Positions

Included in HyPer 9HV IS:

Amp Superseal 4 POS

Plug Part# 282088-1

Pin Part# 282110-1

Seal Part# 281934-2

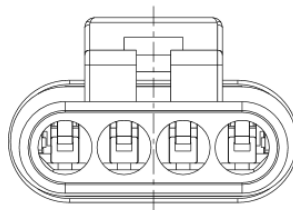

K1-9 K1-33 K1-21 K1-35

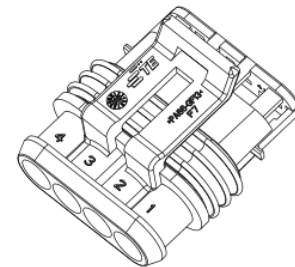

Motor Encoder - 4 Position Connector		
Pin	Name	Position
4	Encoder I/O Ground	K1-9
3	Encoder Cos 1	K1-33
2	Encoder Sin 1	K1-21
1	+5V Out	K1-35

Motor Thermistor Pin Positions

Included in HyPer 9HV IS:

Amp Superseal 2 POS

Plug Part# 282080-1

Pin Part# 282110-1

Seal Part# 281934-2

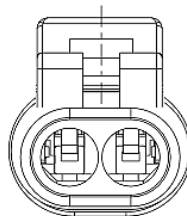

K1-32 K1-12

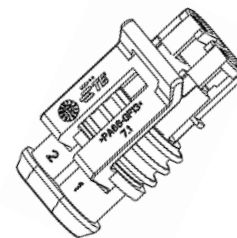

Motor Thermistor - 2 Position Connector		
Pin	Name	Position
2	Motor Thermistor	K1-32
1	Analog Ground	K1-12

NetGain Motors, Inc.

800 South State Street / Suite 4 / Lockport, IL 60441 / 630-243-9100 / 630-685-4054 (FAX)

X144 Main Contactor Wiring

12/24V Coil Driver, High Voltage Contacts, and Key Switch In

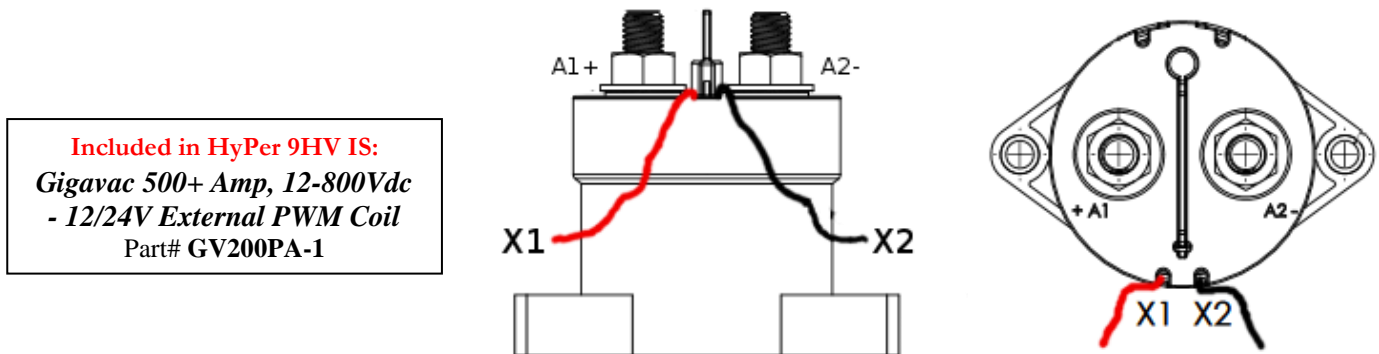

X144 Main Contactor – External PWM		
Terminal	Name	X144 Position
X2	Driver Output 1	K1-26
X1	Coil Return	K1-25
A2-	Controller HV+	B+ Terminal*
A1+	Precharge	B+ Precharge**

* This HV circuit should include proper fuses and disconnect switches.

NetGain Motors, Inc.

800 South State Street / Suite 4 / Lockport, IL 60441 / 630-243-9100 / 630-685-4054 (FAX)

Compact Display Pinout

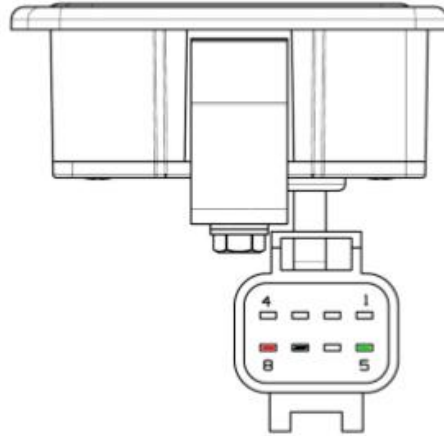

Figure 5 Compact Display Male Connector

Compact Display Mating Female Plug

Not Included in HyPer 9HV IS:

Econoseal .070 MK-II 8 POS

Plug Part# 2822393-1 or 174982-2

Pin Part# 171662-1 or 171630-1

Locking Plate Part# 174983

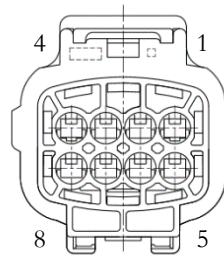

Compact Display - 8 Position Connector		
Pin	Name	Position
8	+12V Out	K1-10
7	I/O Ground	K1-12
6	Not Connected	N/A
5	LIN-BUS	K1-15
4	Digital Input 1	TBD
3	Digital Input 2	TBD
2	Digital Input 3	TBD
1	Digital Input 4	TBD

NetGain Motors, Inc.

800 South State Street / Suite 4 / Lockport, IL 60441 / 630-243-9100 / 630-685-4054 (FAX)

Pre-startup Steps

Download SME Smarview Sys Program:

http://www.go-ev.com/downloads/smartview_sys_dlr.zip

Download* the Latest Controller Firmware:

http://www.go-ev.com/downloads/clone_files/TAU_SYSYS_A01.D01.00A.bin

Download* Your HyPer 9HV Clone File:

http://www.go-ev.com/downloads/clone_files.html

*Not Compatible with Internet Explorer

Be sure your vehicle's **drive wheels are suspended from the ground** upon initial powerup! Drive wheels **MUST NOT** be in contact with any surface upon initial power up.

Controller **MUST BE** powered off at all times while working with the wire harness. **DO NOT** adjust ampseal connectors or any wires while controller power is switched on.

Open High Voltage disconnect switch while working with High Voltage cables.

If a motor ever revs with no throttle applied, turn off the key switch immediately.

QuickStart Guide

The following number order sequence may be essential to your system and the SmartView program's operation. Please follow all steps carefully and in order. If a problem is encountered, ensure all steps were followed correctly. If all steps are correct and a problem persists, please see [Additional Support](#).

1. Follow the **Wiring Diagram** supplied by your dealer or shown [above](#).
2. Fasten High Voltage Battery leads to the X144 controller's B+ and B- terminals according to the **Wiring Diagram**. This battery voltage must be within range: Minimum: 90V to Maximum: 180V.
3. Do not connect U,V,W motor leads until steps 4-18 are complete.
4. Before switching on the Controller, remove the 35pin connector.



NetGain Motors, Inc.

800 South State Street / Suite 4 / Lockport, IL 60441 / 630-243-9100 / 630-685-4054 (FAX)

5. On the motor encoder's 4 Pin Ampseal connector - ensure the wires and connectors are restrained from movement within the installation area. Also ensure that these wires do not intersect or contact High Voltage cables or the motor's field. Verify correct [wiring of the encoder](#):
 - i. PIN1 is connected to K1-35 (+5V Out).
 - ii. PIN2 is connected to K1-21 (Encoder Sin 1).
 - iii. PIN3 is connected to K1-33 (Encoder Cos 1).
 - iv. PIN4 is connected to K1-9 (Encoder I/O Ground).
6. Check that accessory voltage (12-24V) is connected to K1-24 (Key Switch In) when switching on the Key. This is the only wire on connector K1 that will see voltage from an outside source.
7. Check that Contactor Positive Coil is connected to K1-25 (Coil Return).
8. Check that Contactor Negative Coil is connected to K1-26 (Driver Output 1).
9. Connect Amp 35 pin connector to controller plug K1.
10. Couple the supplied **Null Modem** Serial Cable to the supplied Serial-USB adapter.
11. Connect USB end to PC loaded with SME SmartView Smarview Sys software.
12. Connect female serial end to X144 controller's male serial K3 port.
13. Open [SmartView DLR Sys](#) software.
14. Select Connection type: Normal or Wired. Then select the Serial Port your device driver was installed on.
 - i. Your COM port number set is listed in the Windows Device Manager.
 - ii. Verify that the COM port number is not already used by another software when SmartView is opened.
15. Verify vehicle is in Neutral with wheels suspended from the ground. Then switch on X144 controller via Key Switch. Communication between SmartView and the controller should now be enabled with a prompt to install Firmware.
 - i. If SmartView's home screen options do not appear with a "Manage" block, verify steps 11-15 are followed in order.
16. Once communicating with the Controller, install the downloaded *.bin* Firmware by clicking on:
 - i. Mange ➡ Clone ➡ Firmware Update
 - ii. Browse the Firmware Path and select the most recent Firmware release, which you have previously [downloaded](#).
 - iii. Once this *.bin* file is selected and in the Firmware Path, Click PROGRAM.
 - a. If a Dialog Box prompts "Inverter Function Mismatch" this is correct. Click "YES".

NetGain Motors, Inc.

800 South State Street / Suite 4 / Lockport, IL 60441 / 630-243-9100 / 630-685-4054 (FAX)

- iv. The X144 Controller's "STATUS" light should now be illuminated, and the Home screen will display in SmartView.
17. Install your motor's downloaded clone file by clicking on:
- i. Mange ➔ Clone ➔ Load from file archive to controller
 - ii. Navigate to the file location your [downloaded](#) Clone File was saved in. If no path was selected when downloading the file from, the file will be in your "Downloads" folder. You should only see files with the extension .clon
 - iii. Select the .clon file matching your motor's serial number.
 - iv. Click OK, the clone file LOAD progress will reach 100%
 - v. The Home screen should appear automatically with – Monitor, Diagnose, Configure, and Manage blocks.
18. With the Controller switched on and the Main Contactor closed, SmartView's home screen will be active, click:
- i. Monitor ➔ Real Time Data/Inputs –
 - a. Check that by pressing the **Throttle**, you are able to see the Analog Input 1 and 2 values increase. If not, check the wiring.
 - b. Verify that these values are always between 700mV-4600mV. If values are less than <700mV or greater than >4600mV, please verify wiring.
 - c. If a throttle other than NetGain's HEPA is being used, a custom throttle map is required to match your throttle. Please refer to [Post Startup Steps](#) to adjust the [Throttle Mapping](#).
 - ii. Monitor ➔ Real Time Data/Inputs –
 - a. Check that by selecting the **Forward** Direction, the Digital Input 2 (K1-5) switches on (light green). If not, check the wiring.

 - iii. Monitor ➔ Real Time Data/Inputs –
 - a. Check that by selecting the **Reverse** Direction, the Digital Input 3 (K1-6) switches on (light green). If not, check the wiring.

 - iv. Monitor ➔ Real Time Data/Inputs –
 - a. If a brake pressure transducer is installed, follow steps b. and c.
 - b. check that by pressing the **Brake**, you are able to see the Analog Input 3 value increase. If not, check the wiring.
 - c. Verify that the starting input value is <900mV with no pressure on the brake pedal. If starting value is >900mV, please refer to [Post Startup Steps](#) to adjust the [Brake Mapping](#).
19. Once steps 4-18 are complete
- i. **Turn off Key Switch and Disconnect High Voltage Supply.**

NetGain Motors, Inc.

800 South State Street / Suite 4 / Lockport, IL 60441 / 630-243-9100 / 630-685-4054 (FAX)

- ii. Connect UVW cables to the ***HyPer 9HV™*** motor. Be sure the vehicle's wheels are suspended from the ground.
 - iii. Re-connect High Voltage Supply.
20. The system should now be fully operational. You can now attempt to spin the motor:
- i. Select the Forward Direction
 - ii. Press the Throttle and notice the Motor driving
 - iii. Press the Brake and notice the Motor braking
21. If the Motor is in Blocked Rotor condition (maximum Current and 0rpm, with possible high frequency noise), switch off the Controller. This means that the encoder wiring or motor phases are wrong. Please, check them.

NetGain Motors, Inc.

800 South State Street / Suite 4 / Lockport, IL 60441 / 630-243-9100 / 630-685-4054 (FAX)

Post-startup Steps

Throttle Mapping

All HyPer-Drive controllers require throttle signal from a 0-5V or 0-12V potentiometer. HyPer 9 Clone Files come pre-programmed with a throttle map for the Prius Hall Effect Pedal Assembly. This pedal provides an output of 1.60V-4.55V. A different potentiometer or pedal assembly will require different minimum and maximum input values be programmed. A user may map any 0-5V throttle pedal to their preference. Follow the steps below to Map your Throttle Pedal.

1. On the SmartView DLR Sys home screen, select Configure ➡ Traction ➡ Throttle ➡ Map/s.
2. View the Analog Input signal from the Throttle. If the throttle is wired correctly, this should be above 800mV without any pressure on the Throttle Pedal.
3. With power off and the vehicle in Neutral - Press on the Throttle pedal and note the change in this Analog Input mV value.
4. Adjust the Forward and Reverse maps accordingly, starting from the lowest left capture point, working right to the highest.

Brake Regen Mapping

Dynamic Brake Pedal Regen is pre-programmed in all HyPer 9HV Clone files. To utilize Dynamic Brake Pedal Regen, a Brake Pressure Transducer must be installed in the system. This Transducer sends a 0-5V signal that the X144 controller is programmed to transfer into Brake Regen Torque. Follow the steps below to Map your Brake Pedal.

1. On the SmartView DLR Sys home screen, select Configure ➡ Traction ➡ Brake/s ➡ Pedal/Handle Brake.
2. View the Analog Input signal from the pressure transducer. If a transducer is wired, this should be above 300mV without any pressure on the brake pedal.
3. Press on the brake pedal and note the change in this Analog Input mV value.
4. Adjust the map accordingly, starting from the lowest left capture point, working right to the highest.

Regen on Neutral Operating Profiles

If the vehicle does not have a brake pressure transducer (or another type of 0-5V potentiometer to control regen), Dynamic Brake Pedal Regen cannot be used.

All systems have the option to use "Regen on Neutral", also known as Single Pedal Driving. Regen on Neutral features are programmed into all HyPer 9HV clone files.

There are 3 separate operating profiles on each controller, each with a different Neutral Regen Torque percentage. These can be cycled through via:

NetGain Motors, Inc.

800 South State Street / Suite 4 / Lockport, IL 60441 / 630-243-9100 / 630-685-4054 (FAX)

1. The Compact Display's (*E/S/H*) button.
or
2. Selector switches.

There three Regen on Neutral values shown below are pre-programmed into HyPer 9HV clone files. These values can be adjusted to suit user preference.

- Profile 1 *E* (End Regen) : 0% (Coast)
- Profile 2 *S* (Some Regen) : 28%
- Profile 3 *H* (High Regen) : 40%

Neutral Torque Mapping

Follow the steps below to adjust these Neutral Regen Torque values.

1. On the SmartView DLR Sys home screen, select Configure ➔ Traction ➔ Torque Limits ➔ By Other.
2. Under “Limit By Operating Profile” - adjust the Regen Torque by Neutral to suit your preference.

Battery Mapping

The X144 controller can accept high voltage power from any DC supply with limits between 62V-132V. The controller can estimate a battery’s state of charge based off a specified Voltage Map. Follow the steps below to Map your battery pack.

1. On the SmartView DLR Sys home screen, select Configure ➔ System ➔ Battery ➔ Datasheet.
2. Under “Type” – select Lead Acid or User Defined.
3. Enter your Battery Pack’s Capacity and Nominal Voltage.
4. Adjust the state of charge percentage levels based on the minimum and maximum charge values of your Battery Pack.

HyPer 9HV Motor Temperature Derating

The HyPer 9HV Motor contains Permanent Magnets. These magnets are rated up to a temperature of 170°C. To ensure proper protection from overheating the magnets, the controller is programmed to de-rate power based on the motor’s temperature.

Operating ambient temperature range: -40°C to +120°C

Linear power derating: +135°C (100% current) to +155°C (30% current)

Thermal Shut Down: +165°C

NetGain Motors, Inc.

800 South State Street / Suite 4 / Lockport, IL 60441 / 630-243-9100 / 630-685-4054 (FAX)

X144 controller Temperature Derating

To ensure proper protection from overheating, the controller is programmed to derate power based on its heatsink temperature. Additional cooling methods, such as Liquid Cooling, may be required if your controller is overheating under normal operation.

Operating ambient temperature range: -40°C to +55°C

Linear power derating: +80°C (100% current) to +95°C (50% current)

Thermal shut down: +95°C

NetGain Motors, Inc.

800 South State Street / Suite 4 / Lockport, IL 60441 / 630-243-9100 / 630-685-4054 (FAX)

Controller Specifications

Controller Communication

- **RS-232**
- **Lin Bus**
- **CAN:**
 - **Protocol:** CAN Open
 - **Physical layer:** ISO11898-2
 - **Baud rates:** 1Mbps, 800kbps, 500kbps, 250kbps, 125kbps, 50kbps

Controller EMC

- **EN12895** (Industrial Trucks – Electromagnetic Compatibility)

Controller Safety Certification

- **EN1175-1** (Safety of Industrial Trucks – Electrical Requirements)

The vehicle Owner takes full responsibility of the regulatory compliance of the vehicle system with the controller installed.

Controller Operating Environment Specifications

- **Storage ambient temperature range:** -40°C to +70°C
- **Operating ambient temperature range:** -40°C to +55°C
- **Heatsink operating temperature range:** -40°C to +95°C
 - **With linear derating:** +80°C to +95°C
- **Protection Level:** IP65
- **Vibration:** Tested under conditions suggested by EN60068-2-6 [5g, 10÷500Hz, 3 axes]
- **Shock & Bump:** Tested under conditions suggested by EN60068-2-27
- **Cold & Heat:** Tested under conditions suggested by EN60068-2-1

Mechanical size: 210 x 160 x 85 [mm] • **Weight:** 3.5 kg

NetGain Motors, Inc.

800 South State Street / Suite 4 / Lockport, IL 60441 / 630-243-9100 / 630-685-4054 (FAX)

HyPer-Drive X144 Pre-Programmed I/O

Signal: Inputs and Outputs

- Digital Inputs: 9
- Analog Inputs: 5
- Digital Outputs (ON/OFF): 2
- Driver Outputs (PWM): 4
- Motor Speed/Position Sensor Inputs: 2 (A+B Channels/Sin+Cos Analog)

Controller I/O Table

Refer to following table for a complete X144 controller I/O capabilities. For a pinout of the wire harness included in your HyPer 9HV IS, refer to [Figure 2 – Standard Pinout Order Assignment](#). The following table lists the controller's pre-programmed capabilities.

K1 connector pin-out for AC-X1				
Pin	Name	I/O	Specification	Typical function
1	GND	I/O Ground	Do not exceed 0.5A	Negative Logic Supply
2	CAN-L	CAN BUS	CAN-BUS 1 MBit/s max	CAN L (No internal termination resistor)
3	CAN-L RES	CAN BUS	Connected to CAN-L with a series 120Ohm	Termination resistor
4	DIGITAL INPUT 1	Digital Input	VL<=2V,VH>=4.5V Resistor pull-down(active high) or pull up(active low) ON rated voltage +12V/24V	TO BE ASSIGNED
5	DIGITAL INPUT 2	Digital Input	VL<=2V,VH>=4.5V Resistor pull-down(active high) or pull up(active low) ON rated voltage +12V/24V	TO BE ASSIGNED
6	DIGITAL INPUT 3	Digital Input	VL<=2V,VH>=4.5V Resistor pull-down(active high) or pull up(active low) ON rated voltage +12V/24V	TO BE ASSIGNED
7	DIGITAL INPUT 4	Digital Input	VL<=2V,VH>=4.5V Resistor pull-down(active high) or pull up(active low) ON rated voltage +12V/24V	TO BE ASSIGNED
8	DIGITAL INPUT 5	Digital Input	VL<=2V,VH>=4.5V Resistor pull-down(active high) or pull	TO BE ASSIGNED

NetGain Motors, Inc.

800 South State Street / Suite 4 / Lockport, IL 60441 / 630-243-9100 / 630-685-4054 (FAX)

			up(active low) ON rated voltage +12V/24V	
9	I/O GROUND	I/O Ground	Do not exceed 0.5A	Negative Logic Supply
10	+12V OUT	Supply Output	12V \pm 5% 200mA	12V Supply
11	ANALOG INPUT 1	Analog Input	0÷12V 125K Ω pull-down	TO BE ASSIGNED
12	I/O GROUND	I/O Ground	Do not exceed 0.5A	Negative Logic Supply
13	CAN H	CAN BUS	1 MBit/s max	CAN H (No internal termination resistor)
14	CAN-H RES	CAN BUS	Connected to CAN-H	Connected to CAN-H
15	LIN	Com Input/Output	19.2KBit/s 12V 1,1K Ω Pull-up RX: VL<=3.0V dominant, VH>=7.0V recessive	LIN Display Connection
16	DIGITAL IN 6	Digital Input	VL<=2V,VH>=4.5V Resistor pull-down(active high) or pull up(active low) ON rated voltage +12V/24V	TO BE ASSIGNED
17	ANALOG INPUT 2	Analog Input	0÷12V 125K Ω pull-down	TO BE ASSIGNED
18	DIGITAL IN 7	Digital Input	VL<=2V,VH>=4.5V Resistor pull-down(active high) or pull up(active low) ON rated voltage +12V/24V	TO BE ASSIGNED
19	DIGITAL IN 8	Digital Input	VL<=2V,VH>=4.5V Resistor pull-down(active high) or pull up(active low) ON rated voltage +12V/24V	TO BE ASSIGNED
20	DIGITAL IN 9	Digital Input	VL<=2V,VH>=4.5V Resistor pull-down(active high) or pull up(active low) ON rated voltage +12V/24V	TO BE ASSIGNED
21	ENCODER 1A / ENCODER 1 Sin	Peripheral Input	4V 470 Ω pull-up, VL<=1.5V, VH>=3.4V / 0,5 – 4,5 mV input	Quad Encoder Channel A / Sin/Cos Encoder Sin
22	ANALOG INPUT 3	Analog Input	0÷12V 125K Ω pull-down	TO BE ASSIGNED
23	ANALOG INPUT 4	Analog Input	0÷12V 125K Ω pull-down	TO BE ASSIGNED
24	KEY SWITCH IN	Supply Input	Max = 18V , Min = 7V; Supply consumption: logic board 2A max + coil return 8A max	Positive Supply of the control section of the AC-X144
25	COIL RETURN	Supply Output	(+KEY \pm 0.3V) Do not exceed 8A	Positive Common of Auxiliary
26	DRIVER OUTPUT 1	PWM Output	Active low Internal diode to coil return	Main Contactor, Brake, Valve

NetGain Motors, Inc.

800 South State Street / Suite 4 / Lockport, IL 60441 / 630-243-9100 / 630-685-4054 (FAX)

27	DRIVER OUTPUT 2	PWM Output	Active low Internal diode to coil return	Main Contactor, Brake, Valve
28	DRIVER OUTPUT 3	PWM Output	Active low Internal diode to coil return	Main Contactor, Brake, Valve
29	DRIVER OUTPUT 4	PWM Output	Active low Internal diode to coil return	Main Contactor, Brake, Valve
30	DIGITAL OUTPUT 1	Digital Output	active low No internal diode to coil return	Buzzer-Fan-ON/OFF valve
31	DIGITAL OUTPUT 2	Digital Output	active low pull-down No internal diode to coil return	Buzzer-Fan-ON/OFF valve
32	MOTOR THERMAL PROBE	Analog Input	5V 1K Ω pull-up	Motor Temperature Probe
33	ENCODER 1B / ENCODER 1 Cos	Peripheral Input	4V 470 Ω pull-up, VL \leq 1.5V, VH \geq 3.4V / 0,5 – 4,5 mV input	Quad Encoder Channel B / Sin/Cos Encoder Cos
34	ANALOG INPUT 5	Analog Input	0 \div 12V 125K Ω pull-down	TO BE ASSIGNED
35	+5V OUT	Supply Output	5V \pm 5% 200mA	12V Supply





NetGain Motors, Inc.

800 South State Street / Suite 4 / Lockport, IL 60441 / 630-243-9100 / 630-685-4054 (FAX)

Diagnostic Code Guide

The **HyPer-Drive X144™** may indicate Fault Codes ranging from *al no.1* to *al no.107*. If the controller is in a fault condition, the Diagnostic Code can be retrieved through your Compact Display, CANBUS Communication, or through any version of the SmartView Software. A list of each code and its level is provided below. For further information on these codes, please refer to the Diagnose tier of SmartView's Help  section, and click on any Fault name for a troubleshooting guide.

- **Level:** anomalous working conditions are indicated by different alarm levels, classified as follows, depending on their effects on the system:

Level	Priority	Action	Icon
Blocking	1 (THE HIGHEST)	<ul style="list-style-type: none"> • Main Contactor: Opened • Motors: Disabled • Outputs: Disabled 	
Stopping	2	<ul style="list-style-type: none"> • Main Contactor: Closed • Motors: Stopped • Outputs: Enabled 	
Limiting	3	<ul style="list-style-type: none"> • Main Contactor: Closed • Motors: Limited • Outputs: Enabled 	
Warning	4 (THE LOWEST)	<ul style="list-style-type: none"> • Main Contactor: Closed • Motors: Enabled • Outputs: Enabled 	
Ready	No Faults	<ul style="list-style-type: none"> • Main Contactor: Closed • Motors: Enabled • Outputs: Enabled 	

NetGain Motors, Inc.

800 South State Street / Suite 4 / Lockport, IL 60441 / 630-243-9100 / 630-685-4054 (FAX)

Code	Fault	Set Condition	Level
1	<u>Over Voltage</u>	Key-switch voltage or capacitors voltage is above the maximum level allowed for the controller.	Blocking
2	<u>Under Voltage</u>	Key-switch voltage or capacitors voltage is below the minimum level allowed for the Controller.	Blocking
3	<u>User Over Voltage</u>	Key-switch voltage is above the maximum level defined by the user via related parameter.	Blocking
4	<u>User Under Voltage</u>	Key-switch voltage is below the minimum level defined by the user via related parameter.	Blocking
5	<u>Inverter 1 Over Current</u>	Inverter 1 phase current exceeded its current limit.	Blocking
6	<u>Inverter 2 Over Current</u>	Inverter 2 phase current exceeded its current limit.	Blocking
7	<u>Not Assigned</u>	-	-
8	<u>Inverter 1 Over Temperature</u>	Inverter 1 power module temperature is above +100°C.	Blocking
9	<u>Inverter 2 Over Temperature</u>	Inverter 2 power module temperature is above +100°C.	Blocking
10	<u>Inverter 1 High Temperature</u>	Inverter 1 power module temperature is above +80°C.	Limiting
11	<u>Inverter 2 High Temperature</u>	Inverter 2 power module temperature is above +80°C.	Limiting
12	<u>Inverter 1 Under Temperature</u>	Inverter 1 power module temperature is below -40°C.	Blocking
13	<u>Inverter 2 Under Temperature</u>	Inverter 2 power module temperature is below -40°C.	Blocking
14	<u>Inverter 1 Current Sensor Fault</u>	Current sensor of Inverter 1 measures an invalid offset at key on.	Blocking
15	<u>Inverter 2 Current Sensor Fault</u>	Current sensor of Inverter 2 measures an invalid offset at key on.	Blocking
16	<u>Not Assigned</u>	-	-
17	<u>Inverter 1 Temp Sensor Fault</u>	Difference between Inverter 1 and microprocessor temperature greater than 70°C.	Stopping
18	<u>Inverter 2 Temp Sensor Fault</u>	Difference between Inverter 2 and microprocessor temperature greater than 70°C.	Stopping
19	<u>Motor 1 Over Temperature</u>	Motor 1 temperature is above the Motor 1 Over Temperature defined by the user via related parameter.	Stopping

NetGain Motors, Inc.

800 South State Street / Suite 4 / Lockport, IL 60441 / 630-243-9100 / 630-685-4054 (FAX)

20	<u>Motor 2 Over Temperature</u>	Motor 2 temperature is above the Motor 2 Over Temperature defined by the user via related parameter.	Stopping
21	<u>Motor 1 High Temperature</u>	Motor 1 temperature is above the motor Start Cutback Temperature defined by the user via related parameter.	Limiting
22	<u>Motor 2 High Temperature</u>	Motor 2 temperature is above the motor Start Cutback Temperature defined by the user via related parameter.	Limiting
23	<u>Motor 1 Temp Sensor Fault</u>	Motor 1 temperature sensor value is out of permitted range.	Limiting
24	<u>Motor 2 Temp Sensor Fault</u>	Motor 2 temperature sensor value is out of permitted range.	Limiting
25	<u>High Voltage</u>	Key-switch Voltage or Capacitors Voltage is above the Controller Starting Cutback Voltage defined by the user via related parameter.	Limiting
26	<u>Low Voltage</u>	Key-switch Voltage or Capacitors Voltage is below the Controller Starting Cutback Voltage defined by the user via related parameter.	Limiting
27	<u>Microprocessor Over Temperature</u>	Microprocessor temperature is above 125°C.	Blocking
28	<u>+5V Supply Failure</u>	+5V supply is outside the +5V ± 10% range.	Blocking
29	<u>+12V Supply Failure</u>	+12V supply is outside the +12V ± 10% range.	Blocking
30	<u>Encoder 1 Fault</u>	Sin/Cos inputs values are above/below the fault thresholds or spin sensor offset is not right.	Blocking
31	<u>Encoder 2 Fault</u>	Sin/Cos inputs values are above/below the fault thresholds.	Blocking
32	<u>Driver Output 1 Open/Short</u>	Driver Output 1 is either opened or short-circuited.	Blocking
33	<u>Driver Output 2 Open/Short</u>	Driver Output 2 is either opened or short-circuited.	Blocking
34	<u>Driver Output 3 Open/Short</u>	Driver Output 3 is either opened or short-circuited.	Blocking
35	<u>Digital Output 1 Open/Short</u>	Digital Output 1 is either opened or short-circuited.	Blocking
36	<u>Digital Output 2 Open/Short</u>	Digital Output 2 is either opened or short-circuited.	Blocking
37	<u>EEPROM Failure</u>	Error during read/write operation in EEPROM memory.	Blocking
38	<u>EEPROM Corrupted</u>	Memory CRC doesn't match.	Blocking
39	<u>Driver Output 4 Open/Short</u>	Driver Output 4 is either opened or short-circuited.	Blocking

NetGain Motors, Inc.

800 South State Street / Suite 4 / Lockport, IL 60441 / 630-243-9100 / 630-685-4054 (FAX)

40	PreCharge Circuit Fault	Pre-charge of internal line capacitors is too fast or capacitors voltage is fixed to zero during precharge.	Blocking
41	PreCharge Failed	Pre-charge phase fails to charge capacitors till the voltage level of key input.	Blocking
42	Main Contactor Welded	Before closing the line contactor, internal capacitors are loaded for short time and voltage doesn't go down.	Blocking
43	Main Contactor Did Not Close	The difference between key switch and capacitors voltage is too high after the contactor has been powered.	Blocking
44	Interlock Disabled	Interlock input is not active and line contactor is open.	Stopping
45	Static Return to Off Traction	One or more traction inputs are active at the key on, after an Emergency stop or a controlled stop procedure.	Warning
46	Static Return to Off Hydraulic	One or more hydraulic/pump inputs are active at the key on after a controlled stop procedure.	Warning
47	Traction Throttle Fault	A fault condition of traction throttle is detected.	Stopping
48	Hydraulic Throttle Fault	A fault condition of hydraulic/pump throttle is detected.	Stopping
49	Brake Throttle Fault	A fault condition of brake throttle is detected.	Stopping
50	Service Time Expired	Service Timer has expired.	Warning
51	Low Battery State of Charge	Battery state of charge estimated is lower than minimum value defined by the user via related parameter.	Limiting
52	Wrong Parameter	Parameter setting is out of the permitted range.	Blocking
53	Restart Required	Changed a parameter setting.	Blocking
54	Can Bus Off	Bus Off condition detected.	Stopping
55	Can Open Circuit	Messages no longer received.	Stopping
56	Can Bad Wiring or Short Circuit	Can bus synchronization phase failed or bus off condition detected.	Blocking
57	Not Assigned	-	-
58	Not Assigned	-	-
59	Not Assigned	-	-
60	Not Assigned	-	-
61	Not Assigned	-	-
62	Net Timeout Heartbeat	At least one Heartbeat hasn't been received during the startup of the network or after the synchronization phase.	Stopping
63	Net RPDO Timeout	At least one PDO hasn't been received.	Stopping
64	Main Contactor Close Command Timeout	Pre-charge timer has expired before the master sends the power ready request.	Blocking

NetGain Motors, Inc.

800 South State Street / Suite 4 / Lockport, IL 60441 / 630-243-9100 / 630-685-4054 (FAX)

65	<u>Blocking Request From Master</u>	Fault Request is received from Master.	Blocking
66	<u>Not Assigned</u>	-	Not Assigned
67	<u>Net Startup Timeout</u>	The node hasn't been able to synchronize itself to the network.	Blocking
68	<u>Net External Failure</u>	At least one Node has become not operational.	Stopping
69	<u>Net Mains Manager Wrong Sequence</u>	The Main Contactor Manager has executed a wrong powering procedure.	Blocking
70	<u>Net Mains Manager Precharge Too Slow</u>	DC Bus Voltage will not increase after discharging phase.	Blocking
71	<u>Net Mains Manager Closing Too Slow</u>	The main contactor doesn't close.	Blocking
72	<u>Net Mains Manager Powering Alarm</u>	At least one fault has occurred on Main Contactor Manager Controller.	Blocking
73	<u>CO Synchro Failed</u>	At least one node of the network could be wrong configured or switched off.	Blocking
74	<u>CO Synchro Lost</u>	At least one node of the network could be wrong configured or switched off during operation.	Stopping
75	<u>Stopped For System Fault</u>	Node is stopped because another node has a stopping/blocking fault condition.	Stopping
76	<u>Blocked for System Fault</u>	Node is blocked because another node has a stopping/blocking fault condition.	Blocking
77	<u>BMS Wall Charge</u>	The TAU Node sets a blocking fault.	Blocking
78	<u>BMS Stop</u>	The TAU Node sets a stopping fault	Stopping
79	<u>BMS Fault</u>	The TAU Node sets a blocking fault.	Blocking
80	<u>BMS Limiting</u>	The TAU Node limits its current to the required value from BMS.	Limiting
81	<u>Steering Sensor Fault</u>	A fault condition of steering sensor is detected.	Limiting
82	<u>CAN Protocol Run Time Error</u>	Wrong Request for Driver Outputs	Limiting
83	<u>Programming Required</u>	Controller Firmware Programming	Blocking
84	<u>DigInputs Overvoltage</u>	Digital Input Supply has reached dangerous value	Blocking
85	<u>Inverter Model Not Supported</u>	Inverter model is not supported by the firmware.	Blocking
97	<u>Commission In Progress</u>	Spin sensor commission is in progress	Warning

NetGain Motors, Inc.

800 South State Street / Suite 4 / Lockport, IL 60441 / 630-243-9100 / 630-685-4054 (FAX)

98	Commission End Success	Spin sensor commission end successfully	Stopping
99	Commission End Errors	Spin sensor commission end with errors	Stopping
100	Internal Software Fault 1	Internal Error.	Blocking
101	Internal Software Fault 2	Internal Error.	Warning
102	Internal Software Fault 3	Internal Error.	Warning
103	Internal Hardware Fault 1	Internal Error.	Blocking
104	Internal Hardware Fault 2	Internal Error.	Blocking
105	Internal Hardware Fault 3	Internal Error.	Blocking
106	Internal Hardware Fault 4	Internal Error.	Blocking
107	Internal Software Fault 4	Internal Error.	Blocking

Additional Support

If you need additional support to solve Diagnostic Codes signaled by the firmware or strange behaviors of the vehicle, please contact your Authorized Dealer.

In order to make the collection of information faster, you must provide them:

1. **Product Code** of the Controller.
2. Clone file of the Controller.
3. Screenshots of the **About** Page in the Main Menu.
4. Screenshots of the **Active Faults** Tab in DIAGNOSE
5. Screenshots of the **Faults History** Tab in DIAGNOSE
6. Screenshots of the **Time/Distance** Tab in MONITOR